

Refrigerators and Air Conditioners

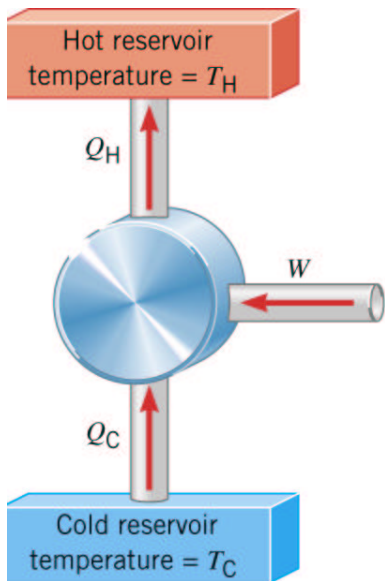

Refrigerators (and air conditioners) are heat engines run backwards. They reverse the natural flow of energy from hot to cold by requiring work be done in moving energy from the cold reservoir and depositing it in the hot reservoir

$$Q_{\text{Hot}} = Q_{\text{Cold}} + W$$

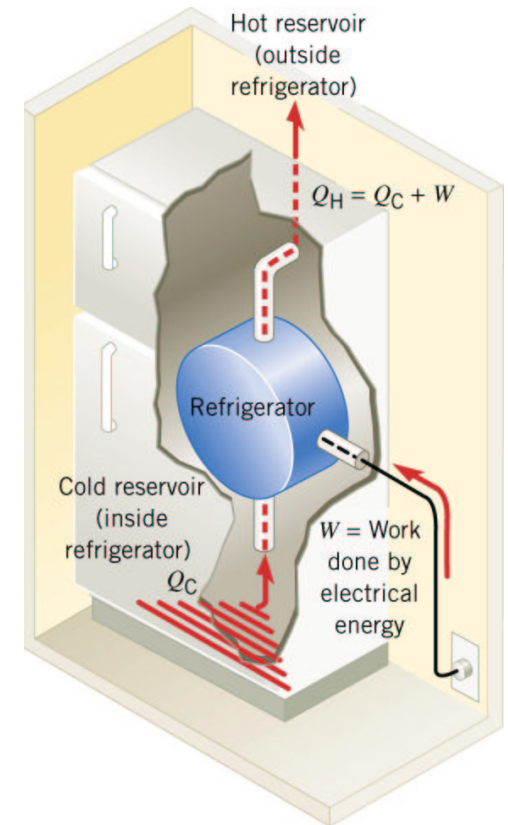

Entropy

Entropy is the term given to the amount of energy unavailable to do work in a non-reversible thermodynamic process. Mathematically, the change in entropy is defined as:

$$\Delta S = \left(\frac{Q}{T} \right)_R$$

where the R stands for a reversible process, T is an absolute temperature, and Q is an amount of heat. It is a measure of how the energy of a system tends to spread out with time.

Entropy is (like internal energy) a function of the state of the system and does not care how it gets from the initial state to the final state. It only depends on the initial and final points.

The SI unit is the Joule / Kelvin.

Entropy (2)

Since the change in entropy is the tendency of energy to spread out with time, it is often called the arrow of time. This means entropy describes how things in nature tend to go.

Entropy is the reason iron rusts, hot pans cool down, paper burns etc.

$\Delta S_{\text{universe}}$ = the total change of
entropy for everything

$\Delta S_{\text{universe}} = 0 \rightarrow$ Reversible

$\Delta S_{\text{universe}} > 0 \rightarrow$ Irreversible

$$\Delta S_{\text{universe}} \geq 0$$

Energy Unavailable to do Work

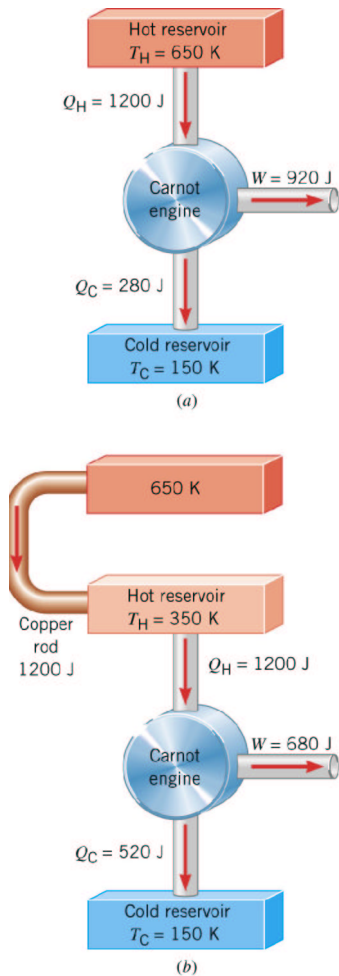

Compare the top and bottom figures. The top one is composed of a reversible process (the Carnot Engine) while the bottom one is a two stage process. The first stage is irreversible and 1200 J of heat flows into the hot reservoir

This causes a entropy change in the universe of 1.6 J/K (which is the change in entropy of the hot reservoir + the entropy change of the cold reservoir). This lowers the temperature of the hot reservoir attached to the Carnot engine.

The efficiency of a Carnot engine is given as: $1 - \frac{T_C}{T_H}$

so if the value of T_H is smaller, the overall efficiency drops.

The total amount of work which can be done for a given heat input is:

$$e = \frac{W}{Q_H} \rightarrow W = e \times Q_H$$

which means if the temperature of the hot reservoir is less, the work able to be done is less.

Entropy (3)

There is also another commonly used definition of entropy. This one involves using entropy to describe order and disorder. This description has limited use and one should be careful to use such generic terms in describing entropy.

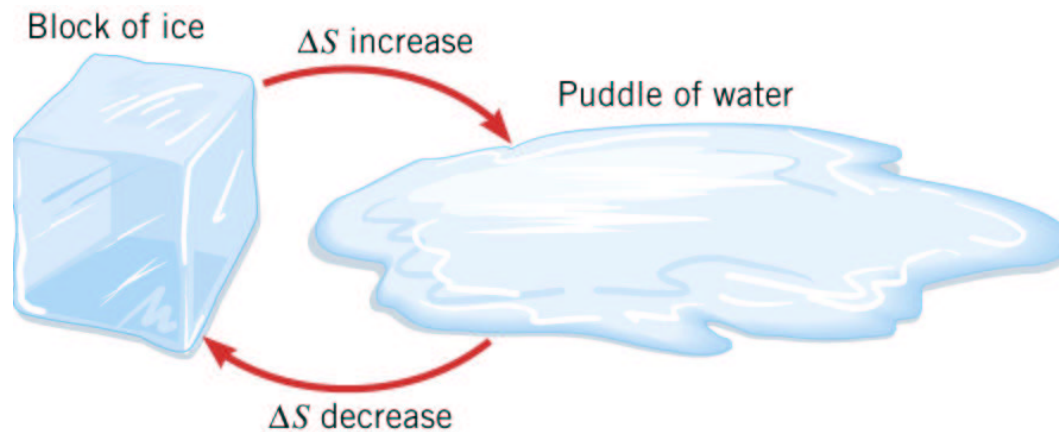

Cutnell & Johnson
Wiley Publishing
Physics 5th Ed.
Figure 15.22 (W562)
C M Y K

The Third Law

Simply stated:

It is not possible to lower the temperature of any system to absolute zero in a finite number of steps.

In other words, the closer you get to absolute zero, the more energy you need to expend to get even closer. Very clever people have used ingenious methods to get us closer and closer to absolute zero.

The lowest temperature reached is: 0.000000001 K. This is very cold indeed.